

C-6

Automatic Transmission



Options

- Transmission Mounted Parking Brake

Approximate Dimensions

Width
20.2 inches (513 mm)

Height
16.4 inches (417 mm)

Face to Mount
22.9 inches (582 mm)

Length
28.9 inches (734 mm)

Length with ZF Brake
32.2 inches (818 mm)

Face to Control Lever
11.5 inches (292 mm)

Bolt Pattern
Ford CSG-649

Warranty

Contact Ford Power Products
for warranty details.

Specifications

Transmission Type	.Hydraulically Controlled (remanufactured)
Torque Capacity	.500 Ft-Lb. (678 Nm) after converter
Torque Capacity (110K)	.256 Ft-Lb. (347 Nm) before converter
Torque Capacity (140K)	.220 Ft-Lb. (298 Nm) before converter
Converter Stall Torque	
Multiplication	.2.0 (110K), 2.3 (140K)
Maximum Fluid Temp	.250 degrees F (121 degrees C)
Continuous	.220 degrees F (104 degrees C)
Installation Angle	.4 to 6 degrees
Weight with Oil Less Brake	.203 lb. (90 kg)
Transmission Fluid	.Mercon
Fluid Capacity	.24 Pints
Engine Usage	.Ford CSG-649 / Ford ESG-642

Gear Ratios

First Gear	.2.46 to 1.00
Second Gear	.1.46 to 1.00
Third Gear	.1.00 to 1.00
Reverse Gear	.2.18 to 1.00

Gear Range Selection

Available Positions P-R-N-D-2-1

Parking Brake

Location Extension Housing

Transmission Controller

Type Hydraulic Valve Body

Standard Features / Benefits

Two Speed or Three Speed Valve Body for first through third; or second and third gears only

Manual Kick-Down Lever providing lower gear selection at higher vehicle speeds

Engine Braking in Manual Low Gears for increased control



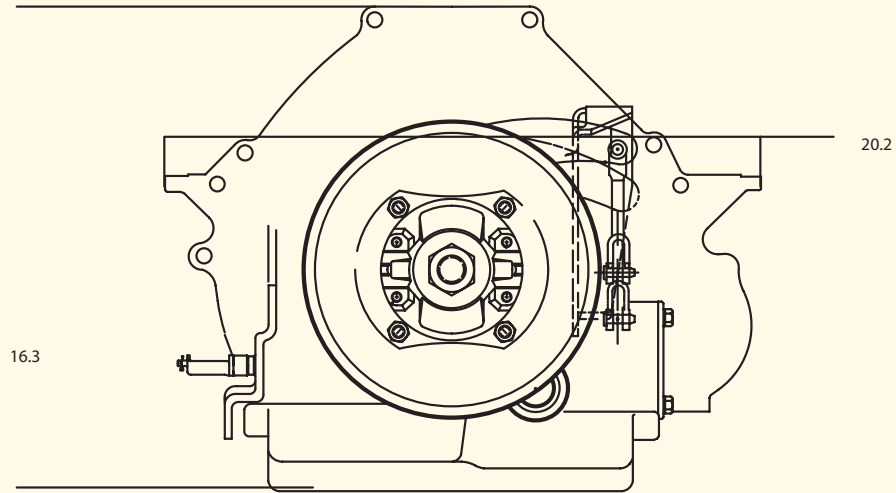

Front End View

Measurements	in
--------------	----

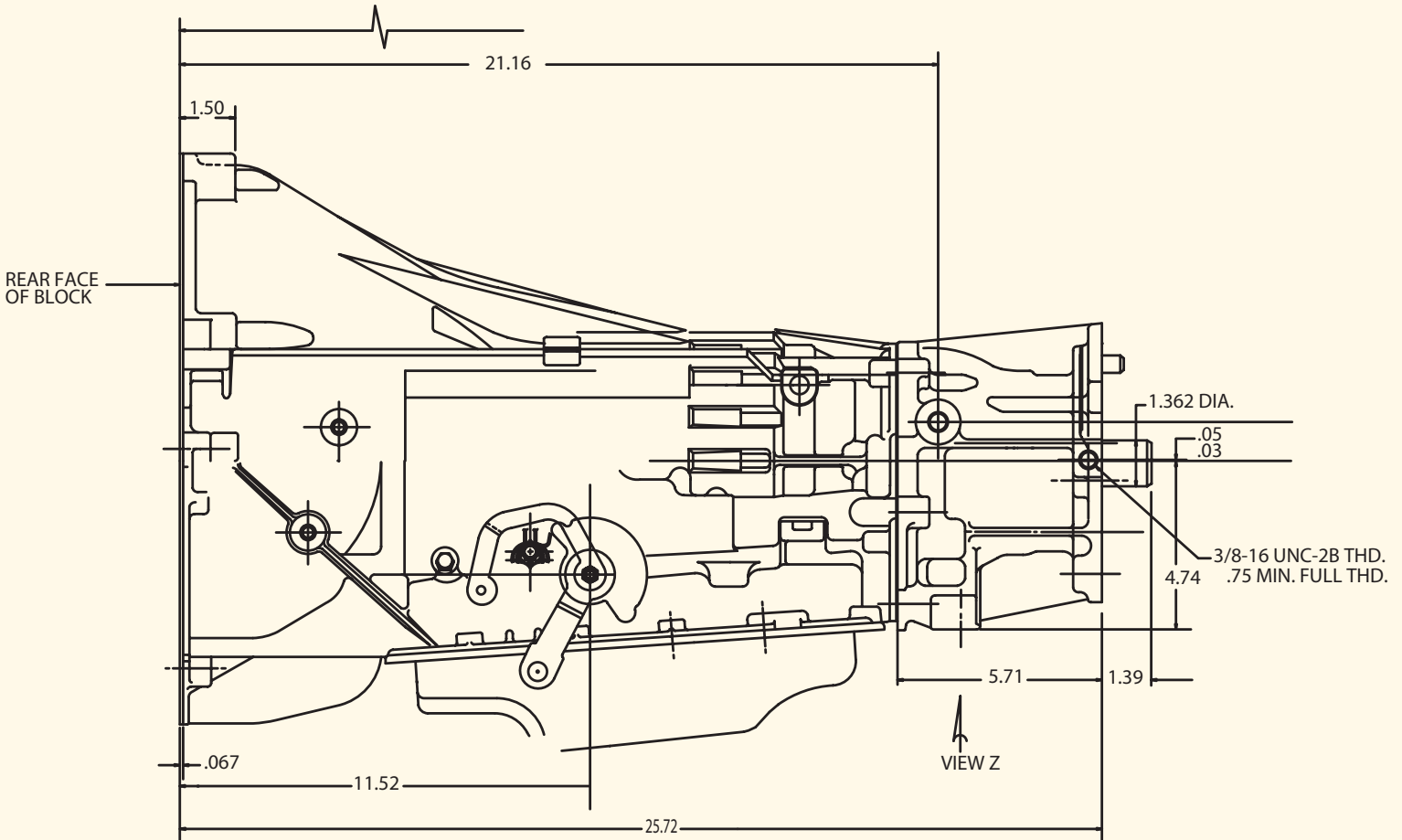

Left Side View

Specifications may vary with application and are subject to change without notice.



Ford Power Products
 15700 Lundy Parkway Drive
 Suite 200
 Dearborn, Michigan 48126
 Phone: 1-800-833-4773
 Fax: 1-313-619-2600

Ford Power Products
 Trafford House, Station Way
 Basildon, Essex, SS16 5XX, England
 Phone: 44 (0)1268 704181
 Fax: 44 (0)1268 702121

Corporate Web Site: www.fordpowerproducts.com

Contact Ford Power Products or your local FPP distributor for additional information